

环保物料

NOTE:

- 1.10 Sprocket hole pitch cumulative tolerance ± 0.20 .
2. Carrier camber is within 1mm in 100mm.
3. Material: black conductive polystyrene alloy.
4. Material Thickness: 0.3 ± 0.05 mm.
5. All dimensions meet EIA-481-B requirements.
6. 5000pcs Pef Reel.
7. For tape width(dim W)16 and 24mm pilot holes are provided on one sides. For tape width(dim W)32, 44 and 56mm pilot holes are provided on both sides.

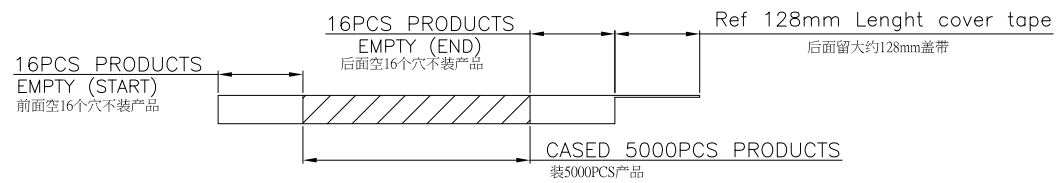
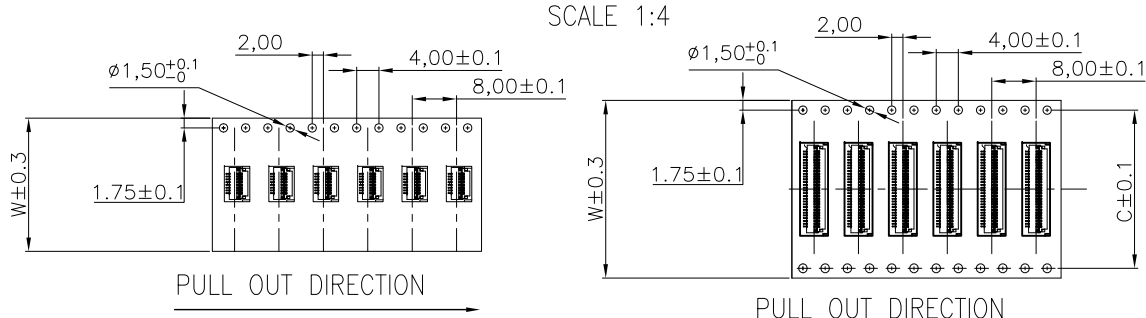
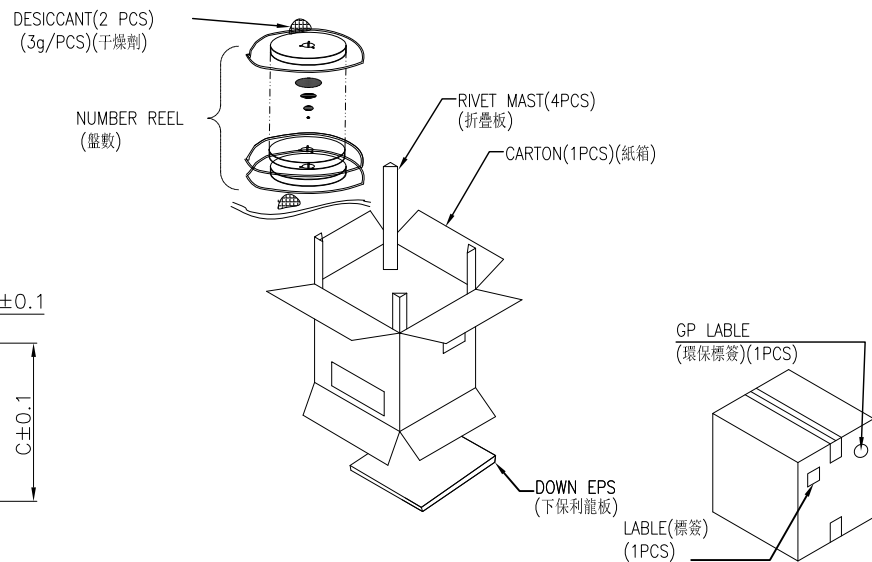
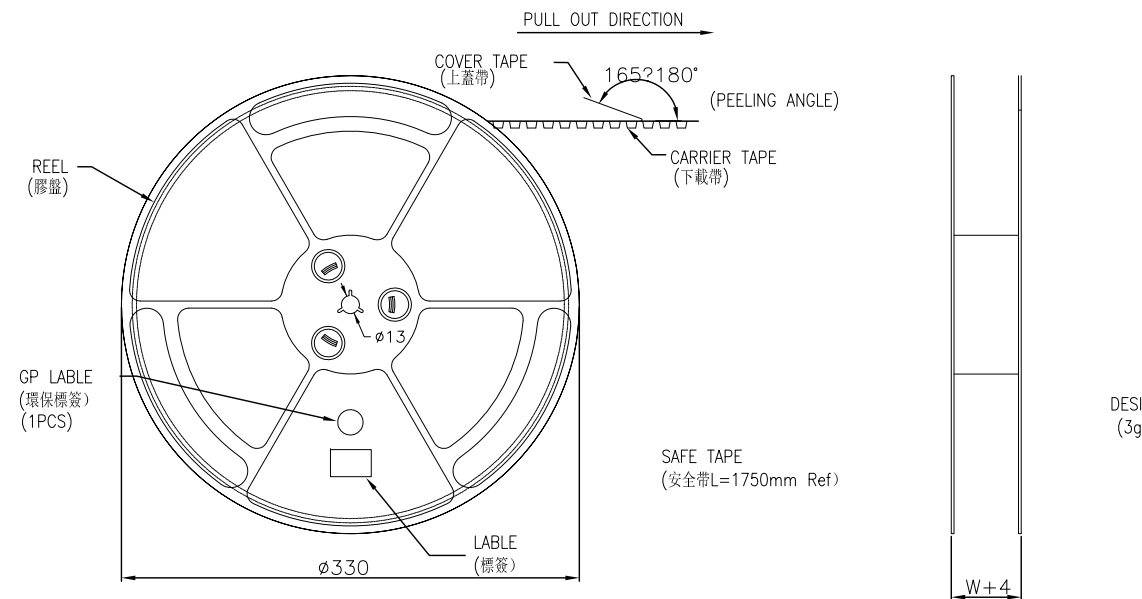

PIN NO.	W	C	PCS /REEL	REEL/CARTON	SUM(PCS)
4PIN~15PIN	16	-	5000	13	65 000
16PIN~30PIN	24	-	5000	9	45 000
31Pin~39PIN	32	28.4	5000	7	35 000
40Pin~50PIN	44	40.4	5000	5	25 000

REV.	REVISION RECORD	DATE	GENERAL TOLERANCES	SCALE	NAME	DATE	PART NO.	DWG NO.	JCTC [®] TERMINAL&CONNECTORS			
A0	新图面发行	17.02.08	LINEAR	1:1			40504W90-NPN-SHLOATBR	ENDE05				
A1	更新图框发行	20.08.21	ANGLES	APPROVED								
A2	依实际更新载带宽度	22.05.17	0.0 ± 0.30	X° REF ± 6°	DESIGNER		TITLE FPC 0.5 Pitch 1.0H ZIF R/A Connector		REV	A2	SHEET	1/1
			0.00 ± 0.25	X° ± 3°	DRAWN	Micky Ma			22.05.17			
			SIZE: A4	0.00 ± 0.10	X° X' ± 2°							